

TENLOS SETUP SHEET XXX CR

Name: _____	Date: _____ Event: _____
City: _____ State: _____	Track: _____
Track <input type="checkbox"/> Indoor <input type="checkbox"/> Tight <input type="checkbox"/> Smooth <input type="checkbox"/> Hard Packed <input type="checkbox"/> Blue Groove <input type="checkbox"/> Wet <input type="checkbox"/> Low Bite <input type="checkbox"/> High Bite Conditions <input type="checkbox"/> Outdoor <input type="checkbox"/> Open <input type="checkbox"/> Rough <input type="checkbox"/> Loose/Loamy <input type="checkbox"/> Dry <input type="checkbox"/> Dusty <input type="checkbox"/> Med Bite <input type="checkbox"/> Other _____	

Front Suspension

Toe: _____
 Ride Height: _____
 Camber: _____
 Caster: _____
 Sway Bar: _____
 Oil: _____
 Piston: _____
 Spring: _____
 Limiters: _____
 Spindle Height: _____
 Axle Spacer: _____
 Steering Type: _____
 Bump Steer: _____
 Camber Link: _____
 Shock Location: _____
 VLA: _____
 Front Wing: _____

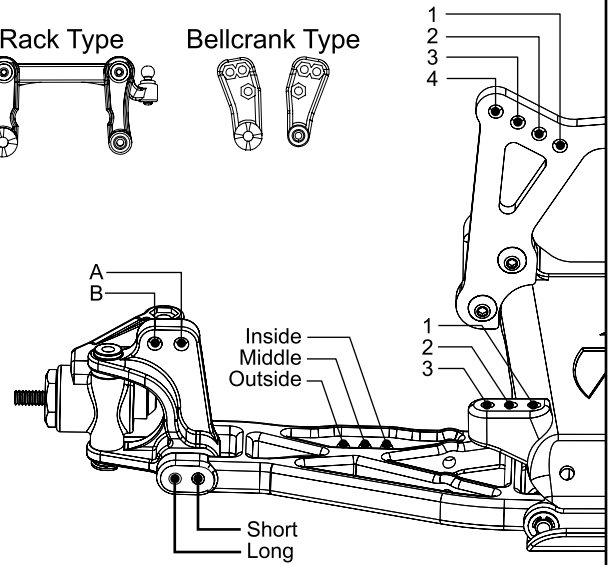
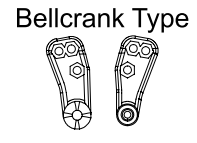
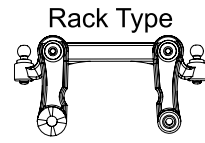

Notes: _____

Rear Suspension

Toe: _____
 Pivot Support: _____
 Ride Height: _____
 Camber: _____
 Rear Hub Spacing: _____
 Drive Shafts/Outdrives: _____
 Sway Bar: _____
 Oil: _____
 Piston: _____
 Spring: _____
 Limiters: _____
 Camber Link: _____
 Shock Location: _____
 VLA: _____
 Wing Position/Mount: _____
 Body & Wing Type: _____
 Battery Position: _____

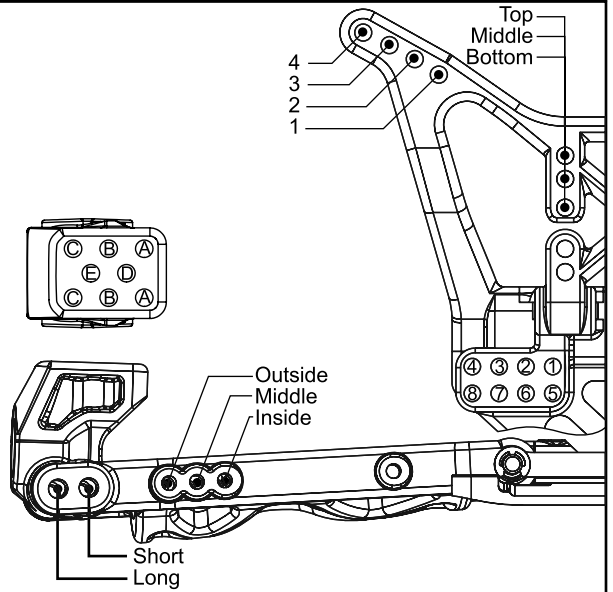

Notes: _____

Weight Placement
(Mark with "X")

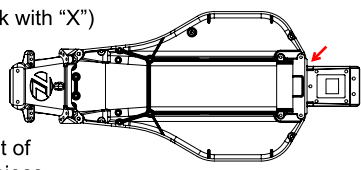

Weight of each piece _____ oz.

Tires:	Type	Compound	Insert	Additive	Motor: _____
Front:	_____	_____	_____	_____	Spur: _____
Rear:	_____	_____	_____	_____	Pinon: _____
Notes:	_____				